



**TMAX-1770-XXX-M M - P I c**

**Features**

- 
- 
- 
- 
- 
- 

**Applications**

- 
- 
- 
- 
- 
- 

**Product Description**

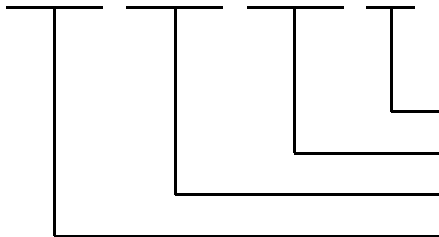

**Dimensions**

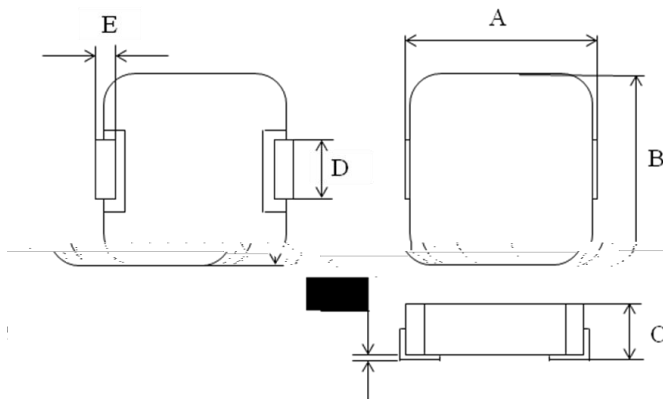

	<b>17.5 Max.</b>
	<b>17.15 Max.</b>
	<b>7.0 Max.</b>
	<b>11.8±0.3</b>
	<b>2.5±0.5</b>
	<b>0~0.30</b>

---

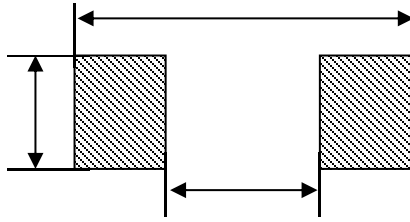
**Recommend Land Pattern Dimensions****Marking**

- 
- 

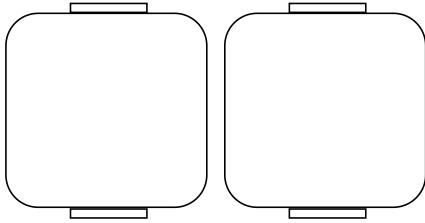

Notes:

**Inductance and Temperature Rise vs. DC Current**

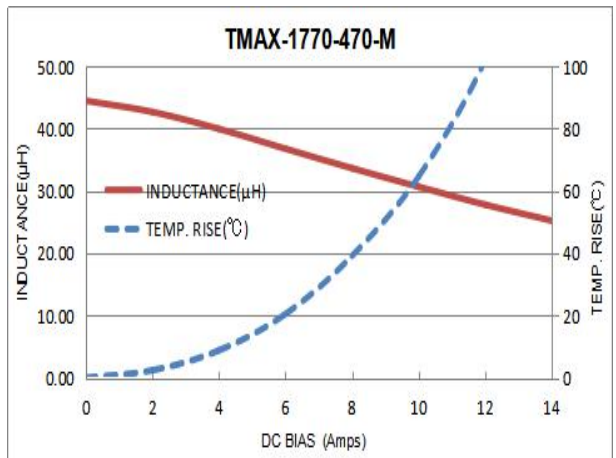
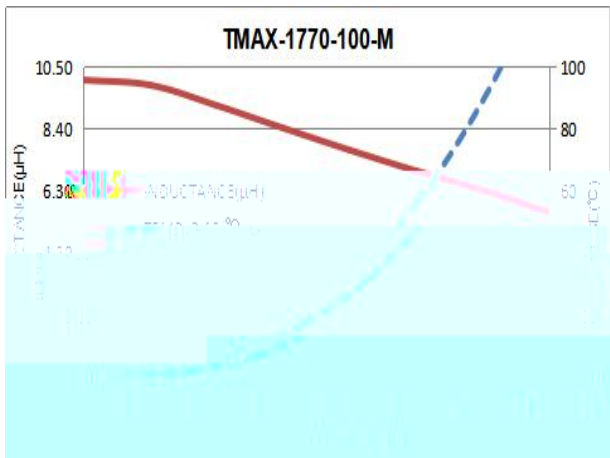
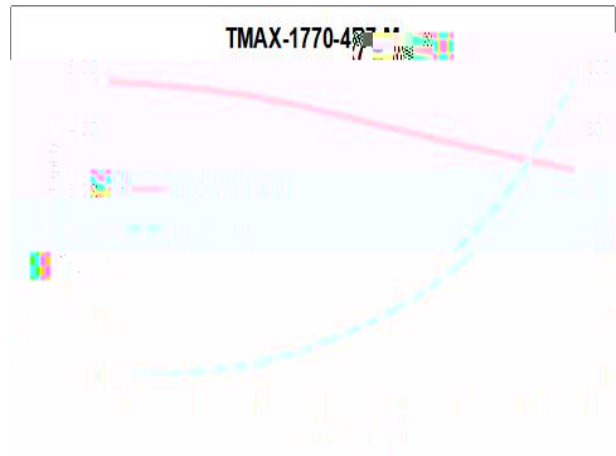
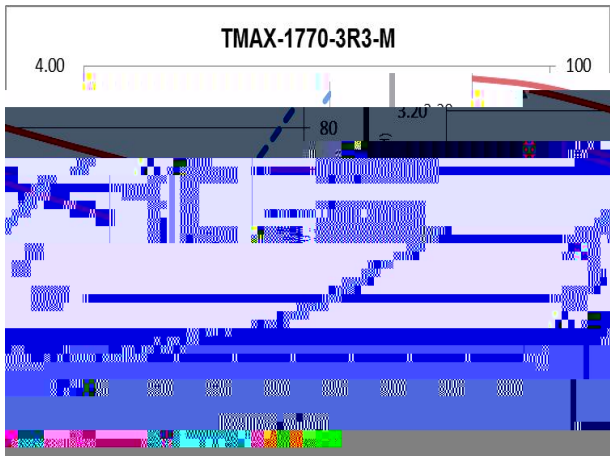

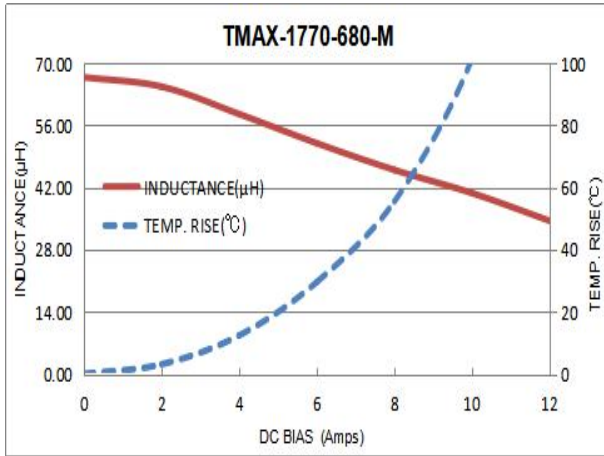

**Reliability:**

Item	Test Method	Specification and Requirement
	± ±      ±	
		±

**Reliability:**

Item	Test Method	Specification and Requirement
	$\pm$ $\pm$ $\rightarrow$ $\rightarrow$ $\pm$ $\pm$ $\rightarrow$	
	$\pm$	$\pm$
	$\pm$	
	$\pm$	
	$\pm$	

**Packaging Dimensions**

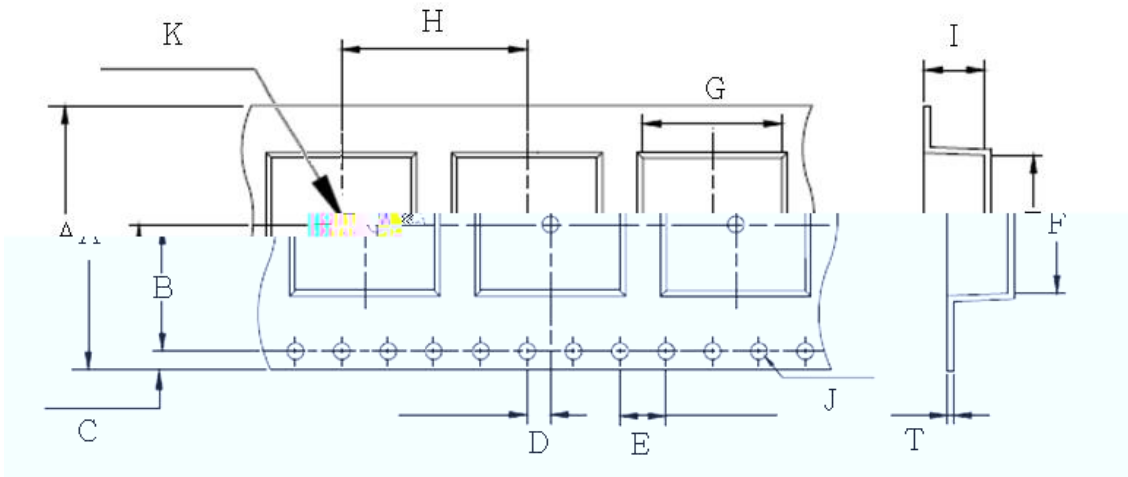

±	±	±	±	±	±
±	±	±	±	±	±

**Reel Dimensions**

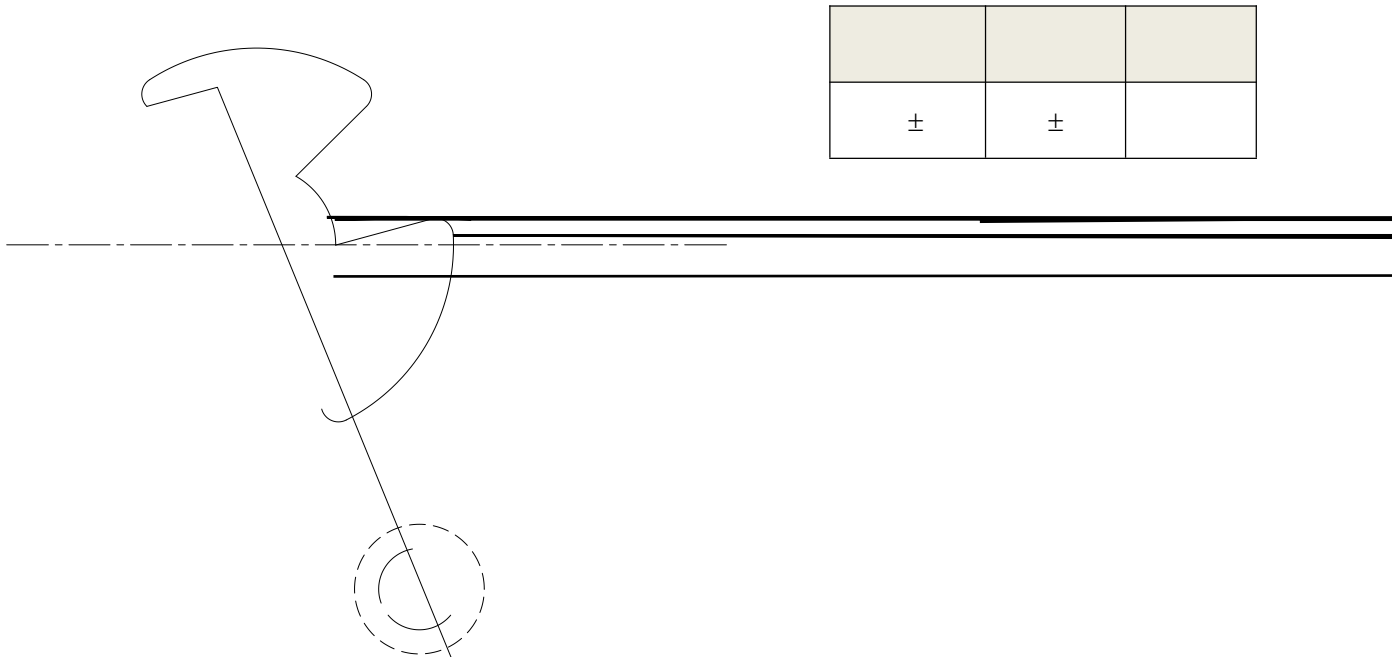

---

**Peeling of top cover tape**

- 
- 

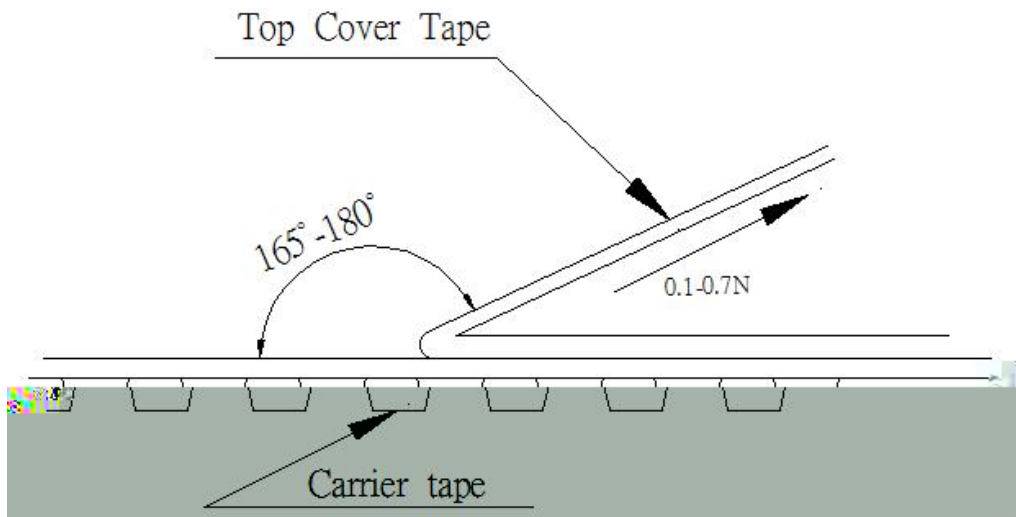





NUMBERS OF COMPANIES  
Label marking

- 
- U
- VR

**Production Label**

**Shipping Label**

- ✓
- ✓
- ✓
- ✓
- ✓

- ✓
- ✓
- ✓
- ✓
- ✓

**Caution note for use**

➤ Storage Condition

➤ Use at temperature

- ✓
- ✓
- ✓
- ✓

Large stylized letters 'n', 'M', 'p', 're' with various characters and symbols overlaid.

Vertical bar

---

**Care note for Safety**

➤

➤

➤

➤

➤

➤

➤